



EN3

EN1866



DEFENSE
EN SERIES OF FIRE EXTINGUISHERS



مصنع نصر عواده
لمعدات الاطفاء و السلامة العامة
Nasr Awwadeh Factory
For Fire Fighting and Safety Equipment

ABC DRY POWDER PORTABLE / WHEELED EXTINGUISHER

ABC Dry Powder is multi-Purpose for all A, B, C and Electrical fire risks. NAF ABC Dry Powder Extinguisher are filled with high performance ABC powder and ideal for residential, commercial and industrial applications.

NAF Wheeled Extinguishers are designed for large industrial or marine fire risk where a large amount of fire extinguishing agent is required.



FEATURES

- All extinguishers are factory filled with %40 ABC Powder consisting of mixture of highly efficient Mono-Ammonium Phosphate and Ammonium Sulfate
- Portable & Wheeled extinguisher are of store pressure type
- Factory filled with high versatile ABC dry powder for great fire knock down
- High UV resistant polyester coating for extra protection from extremely harsh elements
- Easy squeeze-grip operation and all metal handles
- Portable extinguishers are equipped with metal brackets (2kg models with vehicle brackets)
- Portable extinguishers are designed and approved to EN3
- Wheeled extinguishers are designed and approved to EN 1866
- Wheeled extinguishers are suitable for one person operation
- Wheeled extinguishers are equipped with strong and stylish wheel for smooth moving

SPECIFICATIONS & MODELS

Model	NPD2S	NPD6S	NPD9	NPD12	NPD25	NPD50	NPD100
Cylinder Material	DC01	DC01	DC01	DC01	DC01	DC01	DC01
Capacity (KG)	2	6	9	12	25	50	100
Full Weight (KG)	3.60	9.30	13.70	17.40	40	77	140
Height (mm)	383	540	556	672	870	1200	1200
Shell Diameter (mm)	110	154	182	190	250	300	400
Working Pressure (bar)	15	15	15	15	15	15	15
Test Pressure (bar)	27	27	27	27	26	26	26
Approx. Discharge Time (second)	13.5	17	19	30	30	35	35
Approx. Range of Throw (m)	3	5	5	5	11	11	12
Temperature Range	-30 ~ +60 C°	-30 ~ +60 C°	-30 ~ +60 C°	-30 ~ +60 C°	-30 ~ +60 C°	-30 ~ +60 C°	-30 ~ +60 C°
Hose Type	PE	PVC	PVC	PVC	PVC	PVC	PVC
Hose Length (mm)	Nozzle	564	580	680	5000	5000	5000
Fire Rating	13A 89B C	43A 233B C	55A 233B C	55A 233B C	IIB C	IVB C	IVB C
Approved to EN3	✓	✓	✓	✓			
Approved to EN1866					✓	✓	✓



TECHNICAL DRAWING

NPD2S

Part	Description
1	Valve Assembly
2	Dip Tube
3	Powder Cylinder
4	Gasket
5	Pressure Gauge

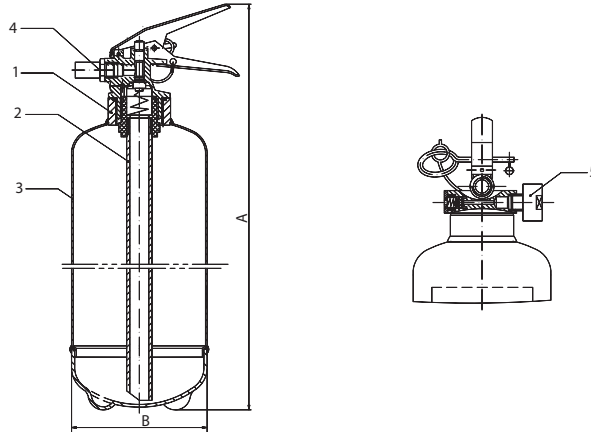

NPD6S - NPD9 - NPD12

Part	Description
1	Valve Assembly
2	Dip Tube
3	Powder Cylinder
4	Hose
5	Pressure Gauge

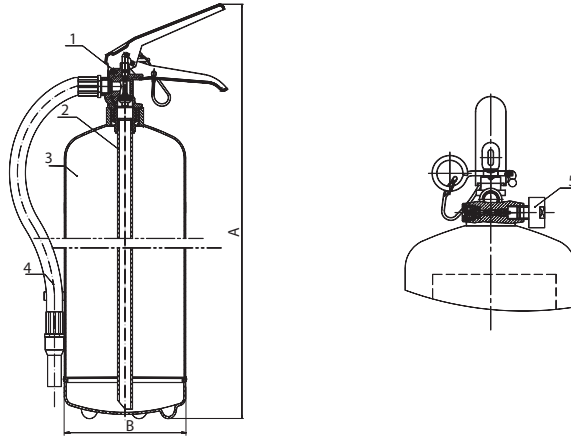

NPD25 - NPD50 - NPD100

Part	Description
1	Valve
2	Trolley
3	Cylinder
4	Nozzle
5	Wheel
6	Hose
7	Pressure Gauge
8	Dip Tube
9	Main Label

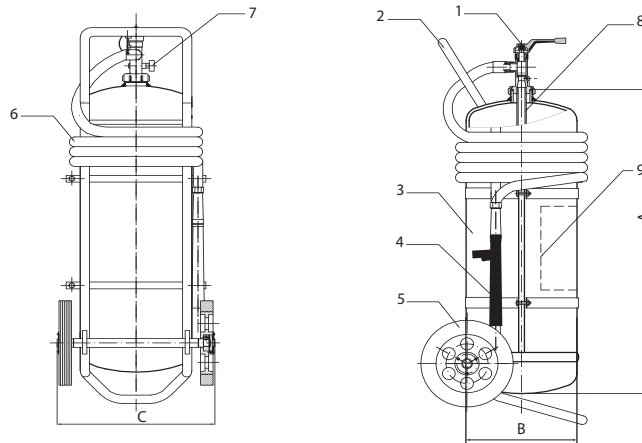

DIMENSIONS (mm)

Model	NPD2S	NPD6S	NPD9	NPD12	NPD25	NPD50	NPD100
A	383	531	551	663	740	870	1210
B	110	154	182	190	250	300	400
C	-	-	-	-	310	440	530

